



# MULTI-FLEX COUPLING (Dimensions)

## New Pipes Connector with Non Axial-Restraint



**Model 3 : MF-RS**  
 (MULTI-FLEX - ROUND  
 STANDARD)



**Model 4 : MF-RL**  
 (MULTI-FLEX - ROUND LONG)

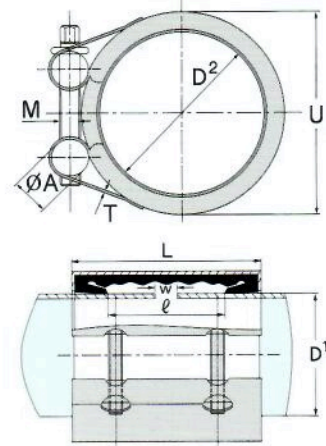

### MF-RS(15A~5,000A)

※ PIPE O.D. specs are available for all sizes.

Size ND	O/D(mm) D1			Range D2	M	L	ℓ	U	W.P		W.T		P.N.(kgf/cm)	
	Industrial	Ship	Industrial						Ship					
15A 1.2"	21.3	21.7	22.0	O/D±0.3	M6 × 40L	57	32	37	40	20	0.16	0.16	3~5 (30~50)	
20A 3/4"	26.9	26.7	27.2	O/D±0.5	M6 × 40L	57	32	46	40	20	0.2	0.2	3~5 (30~50)	
25A 1"	33.4	33.7	34.0	O/D±0.6	M6 × 40L	57	32	51	40	20	0.2	0.2	4~6 (40~60)	
32A 1-1/4"	42.2	42.4	42.7	O/D±0.6	M8 × 45L	57	32	62	40	20	0.3	0.3	5~8 (50~80)	
40A 1-1/2"	40.9	44.5	48.3	48.6	O/D±1.0	M8 × 45L	57	32	66	40	20	0.4	0.4	5~8 (50~80)
50A 2"	54.0	57.0	60.3	60.5	O/D±1.0	M10 × 65L	80	46	81	36	18	0.7	0.7	10~12 (100~120)
65A 2-1/2"	66.7	69.0	73.0	76.3	O/D±1.0	M10 × 65L	80	46	100	36	18	0.8	0.8	10~12 (100~120)
80A 3"	79.8	84.0	88.9	89.1	O/D±1.5	M12 × 75L	107	65	115	32	16	1.5	1.5	20~30 (200~300)
90A 3-1/2"	98.0	101.6			O/D±1.5	M12 × 75L	107	65	144	32	16	1.65	1.65	20~30 (200~300)
100A 4"	106.3	108.0	114.3	118.0	O/D±1.5	M12 × 75L	107	65	144	32	16	1.65	1.65	20~30 (200~300)
125A 5"	129.0	133.0	139.8	141.3	O/D±1.5	M14 × 90L	117	71	175	28	14	2.6	2.6	40~50 (400~500)
150A 6"	154.0	159.0	165.2	168.3	O/D±1.5	M14 × 90L	117	71	196	28	14	2.9	2.9	40~50 (400~500)
200A 8"	204.0	216.3	219.1		O/D±2.0	M16 × 120L	155	80	260	24	12	6.4	6.4	60~80 (600~800)
250A 10"	254.0	267.4	273.1		O/D±2.0	M16 × 120L	155	80	300	24	12	6.9	6.9	60~80 (600~800)
300A 12"	304.0	318.5	323.9	325.0	O/D±2.0	M18 × 130L	155	80	350	20	10	8.7	8.7	80~120 (800~1200)
350A 14"	340.0	355.6	377.0	368.0	O/D±2.0	M18 × 130L	155	80	400	20	10	9.5	9.5	80~120 (800~1200)
400A 16"	406.4	414.5	419.0	429.0	O/D±2.5	M18 × 140L	155	94	450	16	-	10.8	-	80~120 (800~1200)
450A 18"	457.2	465.3	480.0		O/D±2.5	M18 × 140L	155	94	500	16	-	11.8	-	80~120 (800~1200)
500A 20"	508.0	516.9	532.0		O/D±3.0	M18 × 140L	155	94	550	14	-	12.6	-	120~150 (1200~1500)

### MF-RL

Size ND	O/D(mm) D1			Range D2	M	L	ℓ	U	W.P		W.T		P.N.(kgf/cm)	
	Industrial	Ship	Industrial						Ship					
15A 1.2"	21.3	21.7	22.0	O/D±0.3	M6 × 40L	72	46	37	40	-	0.35	-	3~5 (30~50)	
20A 3/4"	26.9	26.7	27.2	O/D±0.5	M6 × 40L	72	46	46	40	-	0.4	-	3~5 (30~50)	
25A 1"	33.4	33.7	34.0	O/D±0.6	M8 × 45L	100	64	51	40	20	0.45	0.45	4~6 (40~60)	
32A 1-1/4"	42.2	42.4	42.7	O/D±0.6	M8 × 45L	100	64	62	40	20	0.5	0.5	5~8 (50~80)	
40A 1-1/2"	40.9	44.5	48.3	48.6	O/D±1.0	M8 × 45L	100	64	66	40	20	0.55	0.55	5~8 (50~80)
50A 2"	54.0	57.0	60.3	60.5	O/D±1.0	M10 × 65L	139	99	81	36	18	1.2	1.2	10~12 (100~120)
65A 2-1/2"	66.7	69.0	73.0	76.3	O/D±1.0	M10 × 65L	139	99	100	36	18	1.3	1.3	10~12 (100~120)
80A 3"	79.8	84.0	88.9	89.1	O/D±1.5	M12 × 80L	203	146	115	32	16	2.6	2.6	20~30 (200~300)
90A 3-1/2"	98.0	101.6			O/D±1.5	M12 × 80L	203	146	144	32	16	3.0	3.0	20~30 (200~300)
100A 4"	106.3	108.0	114.3	118.0	O/D±1.5	M12 × 80L	203	146	144	32	16	3.0	3.0	20~30 (200~300)
125A 5"	129.0	133.0	139.8	141.3	O/D±1.5	M14 × 90L	204	138	175	28	14	4.8	4.8	40~50 (400~500)
150A 6"	154.0	159.0	165.2	168.3	O/D±1.5	M14 × 90L	204	138	196	28	14	5.4	5.4	40~50 (400~500)
200A 8"	204.0	216.3	219.1		O/D±2.0	M16 × 120L	255	177	260	24	12	7.0	7.0	60~80 (600~800)
250A 10"	254.0	267.4	273.1		O/D±2.0	M16 × 120L	255	177	300	24	12	11.7	11.7	60~80 (600~800)
300A 12"	304.0	318.5	323.9	325.0	O/D±2.0	M18 × 140L	255	177	350	20	10	15	15.0	80~120 (800~1200)
350A 14"	340.0	355.6	377.0	368.0	O/D±2.0	M18 × 140L	255	170	400	20	10	16.4	16.4	80~120 (800~1200)
400A 16"	406.4	414.5	419.0	429.0	O/D±2.5	M18 × 140L	255	170	450	16	-	18.6	-	80~120 (800~1200)
450A 18"	457.2	465.3	480.0		O/D±2.5	M18 × 140L	255	170	500	16	-	20.4	-	80~120 (800~1200)
500A 20"	508.0	516.9	532.0		O/D±3.0	M18 × 140L	255	170	550	14	-	21.6	-	120~150 (1200~1500)

ND: Nominal Diameter (A)      ℓ: Allowable Shrinkage/Expansion Clearance (m/m)      D1: Actual Outer Diameter of Pipe (m/m)      D2: Min./Max. Allowable Limit for Pipe (m/m)  
 U: Outer Diameter of Coupling (m/m)      M: Fastener Bolt Size/Length (m/m)      W.P: Working Pressure (kgf · cm<sup>2</sup>)      W.T: Weight Per Unit (kg)  
 L: Coupling Width (m/m)      P: Optimum Locking Torque Value Nm (kgf · cm)

※ The specifications are subject to change for quality improvement.